

TRACTO

All information
on mixing units

[TRACTO.COM/RECYCLING](https://tracto.com/recycling)



MIXING- AND
RECYCLING UNIT
MRU250HE

RECYCLING WITH A SYSTEM



ADVANCED TRENCHLESS TECHNOLOGY

ECONOMICAL, SUSTAINABLE, ECO-FRIENDLY

Drilling fluids in HDD technology

The drilling fluid consisting of Bentonite and water for HDD drilling technology has a number of essential functions. It is applied to loosen the soil, support the free cut, discharge the bore spoils and to seal the bore. Furthermore, the HDD drilling fluid stabilises the bore hole, as gravity exerts a permanent pressure on the horizontal bore.

Valuable mixture with no alternative

Due to its special characteristics, bentonite is an indispensable component of the drilling fluid in HDD. Other drilling fluids are unsuitable for horizontal drilling due to the special conditions. High-quality bentonites consist to 60 – 80% of a highly swellable clay mineral called montmorillonite. Correspondingly, the costs for this mineral and for additives, such as polymers, are high. This makes HDD drilling fluid a valuable operating resource.

Recycling is always worthwhile

The processing and reuse of used HDD-drilling fluid by means of efficient recycling technology reduces the consumption of water and bentonite. In the process, the solids, which are absorbed by the drilling fluid during the drilling process are almost completely separated again. This means that the cleaned fluid can be continuously reused in a closed drilling fluid circuit. This accelerates drilling progress, significantly reduces wear on drilling tools and pump and also lowers the consumption of water and

bentonite. Therefore, multiple use of the fluid and separation of the solids through recycling sustainably increase the economic efficiency of a HDD bore.

A question of efficiency

The following applies in principle: the more efficient the recycling system, the lower the costs for operating resources and disposal. Only a high-quality and technically mature recycling technology guarantees the maximum separation of cuttings from the drilling fluid, so that it can be reused without hesitation. The MRU250HE recycling plant from TRACTO was developed and designed with these aspects in mind.

**Recycling
is always
worthwhile**

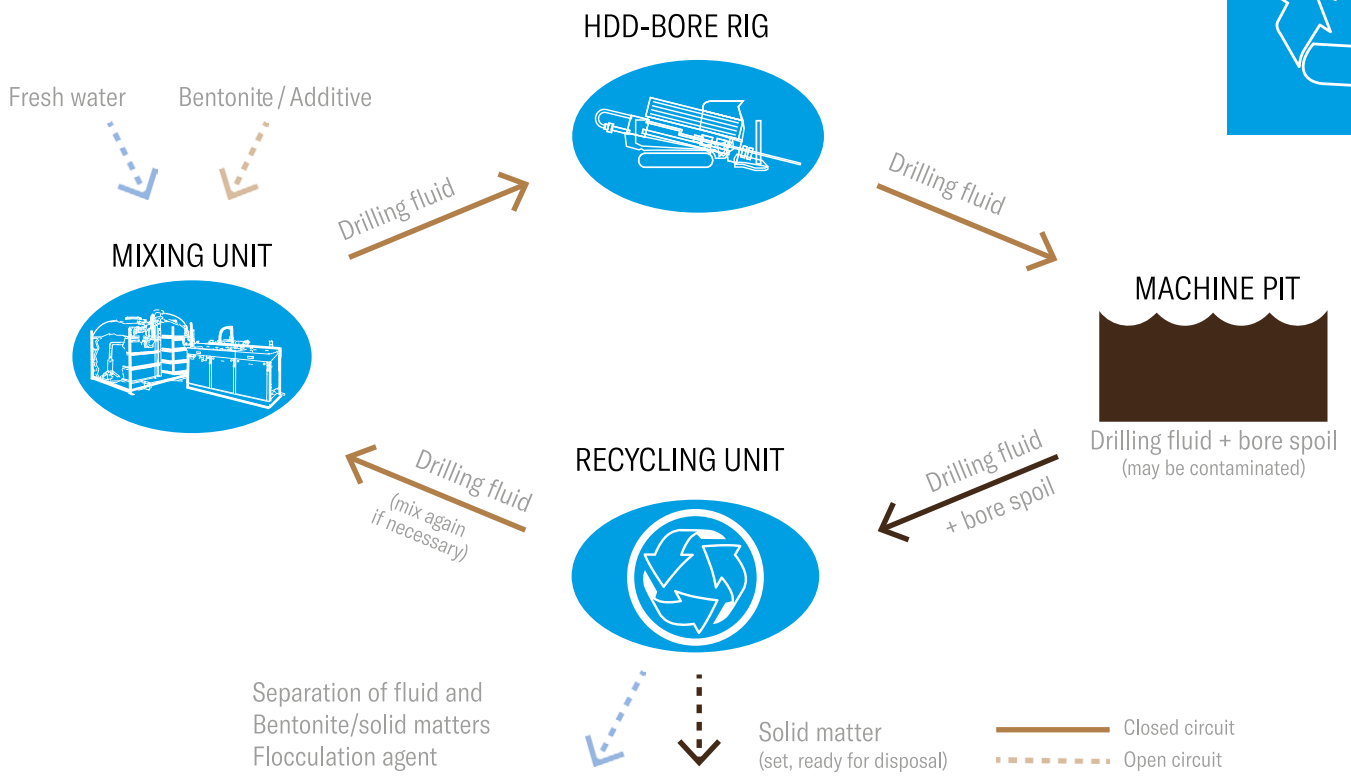
OVERVIEW

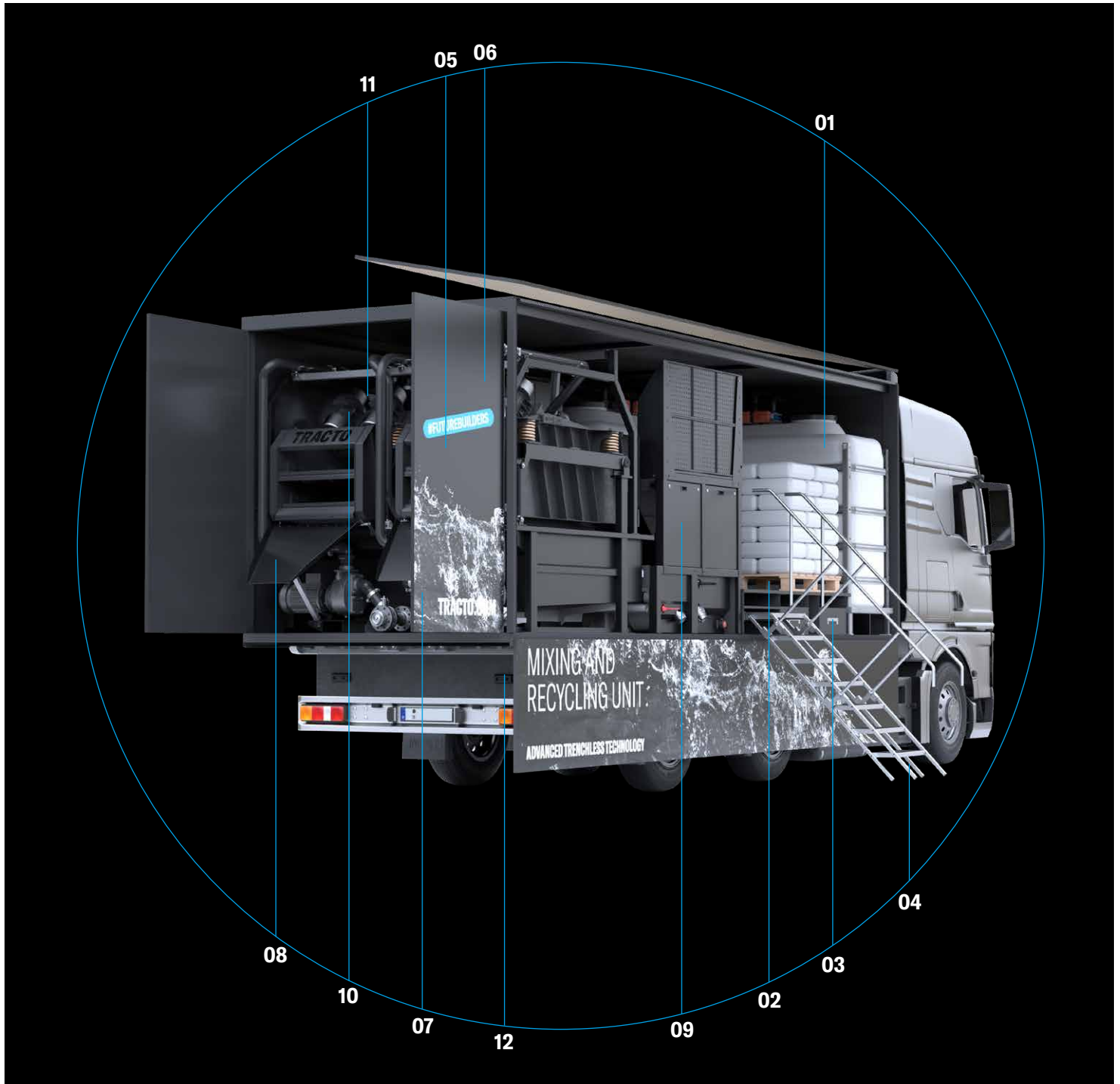

01 Two mixing tanks each with 4000 litres tank capacity with level indicator and integrated distribution system for optimum drilling fluid circulation

02 Pallet storage space for Bentonite and accessories

03 Storage shelves for drilling tools

04 Integrated and foldable stairs for easy access to the work area

05 Separate working space to carry out assembly work and minor repairs

06 500 litres fresh water tank

07 1500-litres-collection tank for used and pre-cleaned drilling fluid

08 Rear side solids chute for screened coarse and fine materials

09 Bentonite funnel with powerful Venturi nozzle and integrated dust extraction for easy mixing of the drilling fluid

10 Inclination-adjustable shakers with large dimensional sieve surfaces for removing coarse solids

11 Hydro-cyclones to remove fine particles

12 Support feet to align and stabilise the vehicle

13 Underfloor power unit to drive the pumps and motors with reduced noise in the truck set-up

IN FIVE SENTENCES

1

Closed circuit

The MRU250HE combines a high-capacity recycling system with a full mixing unit for continuous mixing, conveying and processing of drilling fluid. All components are permanently installed in the truck body and there is ample storage space.

2

Clear conscience

By recycling drilling fluid, you can meet the increasing legal requirements in this area and reuse the drilling fluid with a clear conscience. Advanced technology ensures clean separation and less waste.

3

High-End mixing unit

The MRU250HE is also a fully self-contained mixing unit. Up to 8,000 litres of drilling fluid can be mixed, pumped and stored simultaneously in the two mixing tanks, enabling continuous, virtually uninterrupted operation of the system.

4

Mobile money box

With the mobile system, drilling fluid can be recycled directly on site and reused without downtime. The reduced need for drilling fluid saves money on water, Bentonite, costly additives and disposal.

5

Active environmentalist

Recycling reuses valuable fresh water instead of wasting it. Necessary chemical additives in the drilling fluid are recovered for reuse or can be disposed of in a controlled manner.

EASY-FLOWING: INTELLIGENT CONTROL TECHNOLOGY



Easy monitoring of all processes with clear displays

Many of the mixing unit's functions are automatic or can be remotely controlled to make the job as easy and efficient as possible:

- Various pumps and motors can be controlled directly from the drill rig, as can the supply of drilling fluid to the drill rig.
- Displays on the drill rig and on the mixing unit allow constant monitoring of various functions at the same time, such as the operating status of the power packs, the position of the valves and the filling levels of the collection, mixing and fresh water tanks.
- Intelligent control technology also ensures a smooth process when filling the tanks: When the maximum capacity is reached, the filling process stops automatically, and prevents the tank from overflowing.
- As an option, cameras can be integrated to visually monitor the arrangement of the sieves, ensuring a high degree of separation and flawless operation.

CHARACTERISTICS

Mixing Unit

- Mixing tanks with level indicator and integrated distribution system for optimum drilling fluid circulation
- large Bentonite funnel with powerful Venturi nozzle and integrated dust extraction
- 2 Mixing tanks each with 4000 litres tank capacity
- fast and easy cleaning
- Pallet storage space for Bentonite

Recycling System

- 2 inclination adjustable shakers to remove coarse solids
- Hydro cyclones to remove fine particles
- Collection tank for used and pre-cleaned drilling fluid
- Rear side solids chute for screened coarse and fine material

Additional components

- Integrated workbench with tool wall
- 500 litres freshwater tank
- Filling funnel for feeding additives to optimise the drilling fluid mixture

- Integrated drawers and storage spaces for drilling accessories
- Folding stairs
- High-pressure cleaner
- Optional pit pump for the suction of used drilling fluid from the starting or target pit
- Interior and surrounding lighting
- Auxiliary heating for frost protection
- Monitoring of shaker load via cameras (optional)
- Interface with drilling rigs (for GRUNDODRILL ACS130 / JCS130 and ACS300 / JCS300)
- Pallet storage space for accessories (next to Bentonite)
- Ergonomic operating via pneumatically driven valve flaps
- Remote control via portable panel

Mixing and Recycling Unit
All highlights at a glance



TECHNICAL DATA

MIXING AND RECYCLING UNIT MRU250HD

WEIGHT AND DIMENSIONS

Weight (Complete vehicle)	20 t
Dimensions (Complete vehicle)	ca. 12.000 x 2.550 x 3.950 mm

MIXING TECHNOLOGY

Tank capacity	2 x 4.000 litre
Version	PE Tank with filling level monitoring
Max. feed rate transfer pump	700 l/min
Max. pressure transfer pump	3 bar

RECYCLING SYSTEM

Shaker	2 x Double Decker-Shakers
Screen type	FSMB Panel Screen
Screen size	1.050 x 730 x 25 mm
Screen mesh width	60 - 300 API
Screen quantity (total)	8 pcs. (2 pcs. per level)
Inclination adjustment	manual (hydraulic)
Cyclones	4" and 5"
Max. cleaning capacity	250 l/min
Sand contents	< 0,1 %
Pit pump	Hose pump

POWER UNIT

Engine	Generator
Capacity	45 kVa
Emission standard	Stage V
Installation	Underfloor

FULL SERVICE FOR TRENCHLESS TECHNOLOGY

Whether its before, during or after the purchase, whether in person or online – we are always at your side with advice and support. Our wide-ranged service is specially tailored to the requirements of trenchless pipe installations, so you can concentrate fully on your core business.

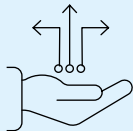

Digital Solutions

Our website offers you the whole world of trenchless technology in digital form. Find out more about our company, our products and their applications. Discover the digital tools for the HDD drilling technology and many other intelligent solutions. Always stay up to date by using the links to our social media channels. Or you can order machines, accessories and spare parts in our eSHOP – easy and conveniently via PC, smartphone or tablet.

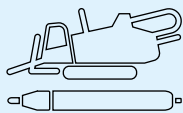

Nodig Product Specialists

You can truly rely on our product specialists for all technical questions regarding the function and application of our steerable and non-steerable NODIG-systems. With comprehensive knowledge in each of their special fields, you can be sure they will find the best solution for your trenchless projects and advise you competently on setting up your jobsite.



Financing

We offer attractive financing solutions for new and used machines to our customers and sales partners through the TRACTO-TECHNIK Finance GmbH. Be it financing, hire purchase, various types of leasing or insurance: we provide extensive expert advice, individually and personally, in order to find the tailored solution for you. Discretion goes without saying.



Training

Qualified training enables you to apply trenchless technology even more effectively and profitably. Our wide range of training courses for machine operators, construction professionals as well as planners and clients cover all aspects of NODIG technology, including special topics. Certified trainers also instruct you, in theory and practice according to your individual requirements, either at one of our numerous company locations, or directly on your own premises or online, independent of time and place.

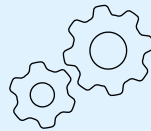

Specialised Civil Engineering Service (Application Technology)

The specialised civil engineering service for application technology provides support for all your trenchless construction sites. Our experts demonstrate the steerable and non-steerable NODIG technology live in practical use, show your drilling teams how to use it or actively assist with special projects.



Geoservice

Precise knowledge of the soil is the key to successful trenchless projects. Our Geoservice team provides you with this professional knowledge. Our expertise puts you in a position to master every type of soil. Based on geoscientific maps and existing construction files, we supply information on the soil, which will help you with calculations or supplements.



Used Equipment

If you want to sell a used machine at an attractive price or are looking for the right equipment for your tasks, our full service for used NODIG machines will take the workload off your hands – from appraisal and price determination to professional repair and certification, through to achieving the best price for you via our used machine website with access to one of the world's largest construction machinery platforms.

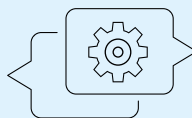

After Sales

Via our worldwide service network we are always there for you, even after the purchase. A total of five TRACTO plants and seven customer centres in Germany, as well as our worldwide sister companies and sales partners guarantee fast supply of spare parts and immediate availability. Our competent service staff offer fast assistance, to ensure you don't lose any time.

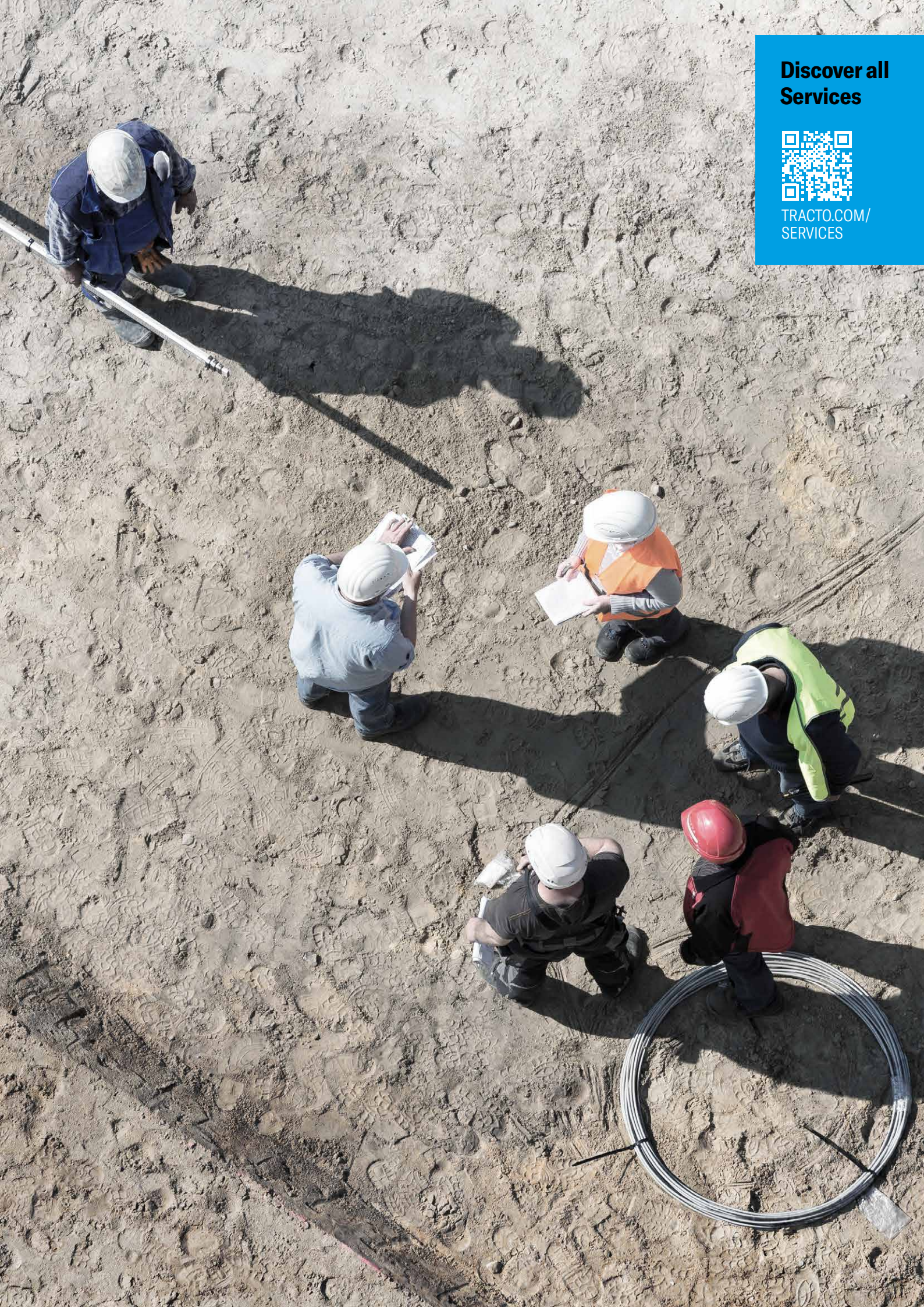

**Discover all
Services**



[TRACTO.COM/
SERVICES](https://tracto.com/services)

**TRACTO-TECHNIK
GMBH & CO. KG
HEADQUARTERS**

PAUL-SCHMIDT-STRASSE 2
57368 LENNESTADT, GERMANY
T +49 2723 808-0
F +49 2723 808-180
INFO@TRACTO.COM
TRACTO.COM/DE



TRACTO.COM

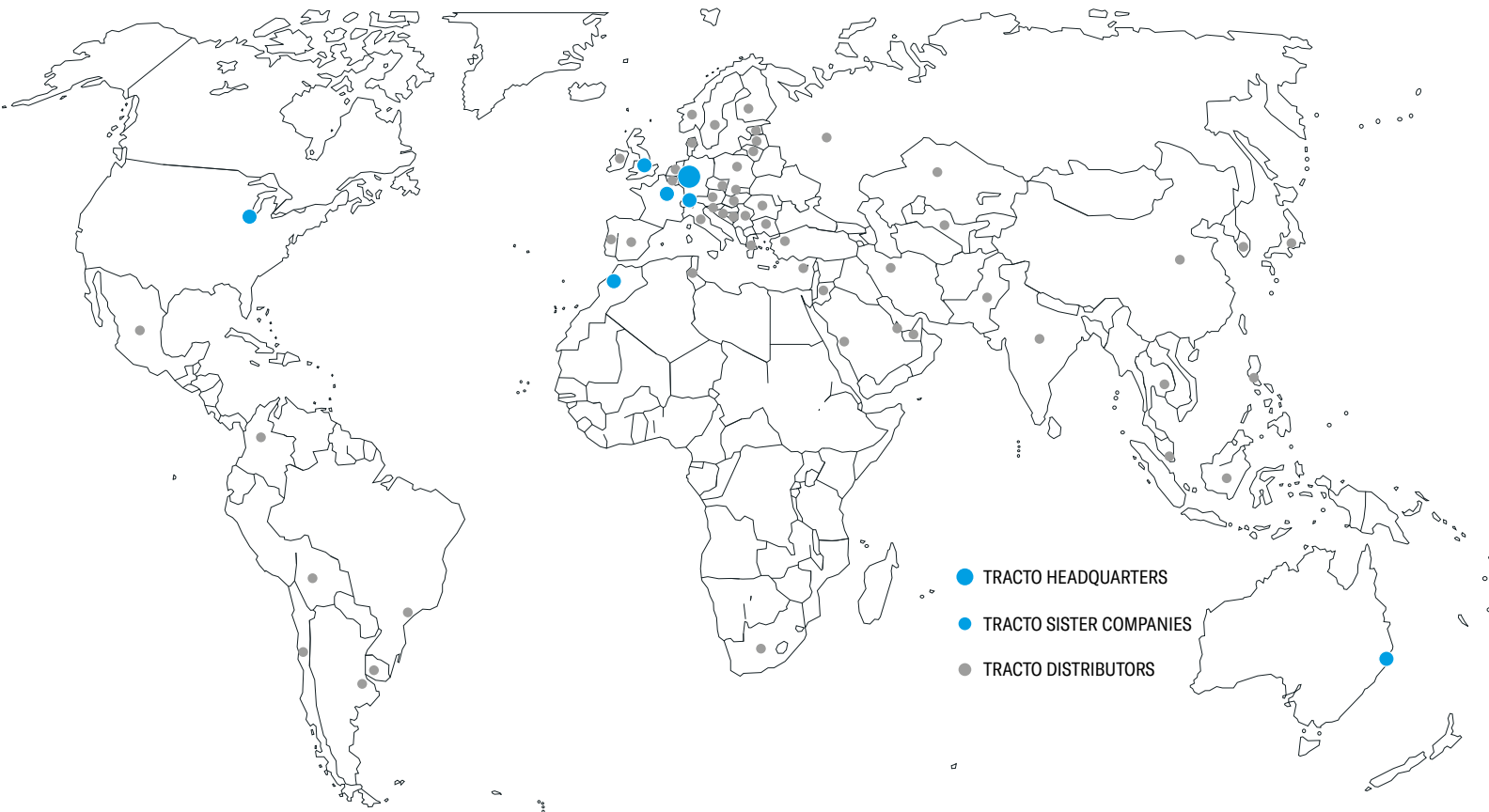

- TRACTO HEADQUARTERS
- TRACTO SISTER COMPANIES
- TRACTO DISTRIBUTORS

SWITZERLAND
TRACTO-TECHNIK SCHWEIZ AG
INDUSTRIESTRASSE 4
8360 ESCHLIKON TG, SCHWEIZ
T +41 79 8203897
CH@TRACTO.COM
TRACTO.COM/CH-FR

UNITED KINGDOM
TRACTO-TECHNIK UK LTD
10 WINDSOR ROAD
BEDFORD MK 42 9SU
T +44 1234 342566
F +44 1234 352184
INFO@TRACTO-TECHNIK.CO.UK
TRACTO.COM/UK

FRANCE
TRACTO-TECHNIK FRANCE S.A.R.L.
1/3 RUE DE LA PRAIRIE
F-77700 BAILLY ROMAINVILLIERS
T +33 1 60 42 49 40
F +33 1 60 42 49 43
FR@TRACTO.COM
TRACTO.COM/FR

USA
TT TECHNOLOGIES INC.
2020 EAST NEW YORK STREET
AURORA, IL. 60502
T +1 630 851 8200
F +1 630 851 8299
INFO@TTTECHNOLOGIES.COM
TTTECHNOLOGIES.COM

AUSTRALIA
TRACTO-TECHNIK AUSTRALIA PTY LTD.
10 ALICIAJAY CIRCUIT
LUSCOMBE, QLD 4207
T +61 7 3420 5455
AU@TRACTO.COM
TRACTO.COM/AU

MOROCCO
TRACTO-TECHNIK AFRIQUE S.A.R.L.
ROUTE DE TAMESNA 4022
POSTE 2044, 12220 TAMESNA
T +212 537 40 13 63 / 64
F +212 537 40 13 65
INFO@TRACTO-TECHNIK.MA
TRACTO.COM/MA

**TRACTO
ADVANCED TRENCHLESS TECHNOLOGY**

TRACTO PARTNER:

Images, text and graphics subject to change. Some of the product or service designations listed below as well as depicted logos are registered trademarks of TRACTO and in these cases are subject to the respective applicable trademark law.